

TYPICAL COUNTY SECTION
 Goodwin Road
 Sta. G-105+00 to G-110+50
 N.T.S.

TYPICAL COUNTY SECTION
 Sunset Hwy Road
 Sta. S-180+25 to S-188+52
 N.T.S.

LEGEND

- ① 0.34' HMA CL 3/8 IN. PG 64-28 (2 lifts)
- ② 0.75' Crushed Surfacing Base Course (CSBC)
- ③ Roadway Excavation Incl. Haul
- ④ Embankment Compaction
- ⑤ Existing Concrete Roadway Approx. 10 Inches
- ⑥ Silt Fence (See Sheets E1-4).

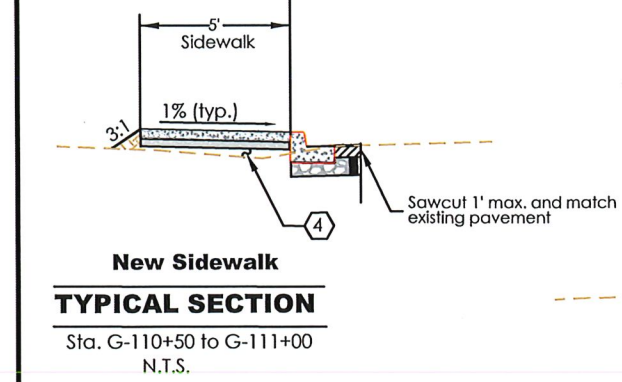

TYPICAL SECTION
 New Sidewalk
 Sta. G-110+50 to G-111+00
 N.T.S.

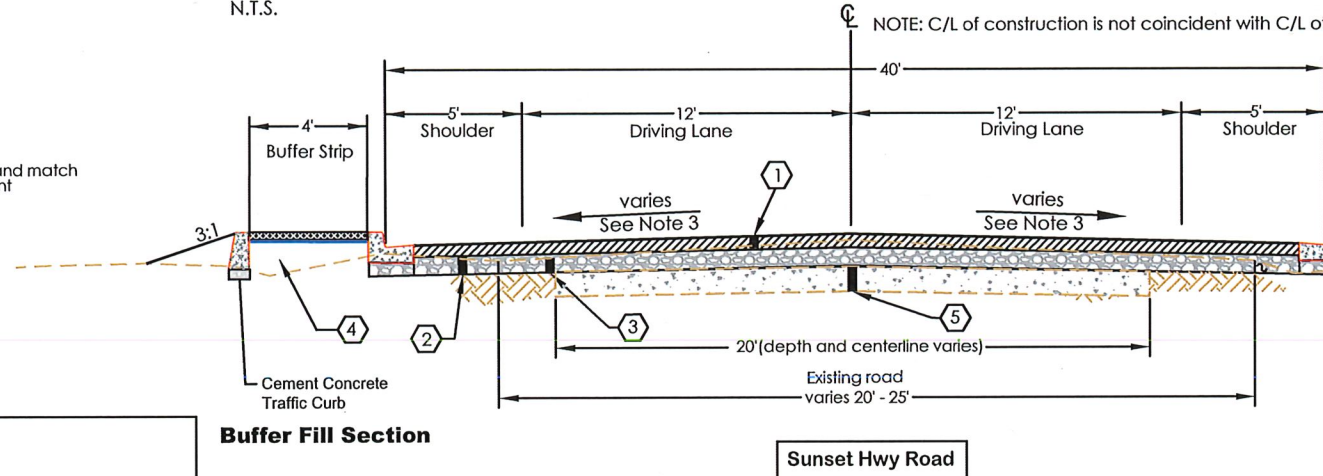

TYPICAL CITY SECTION
 Sunset Hwy Road
 Sta. S-188+52 to S-200+50
 N.T.S.

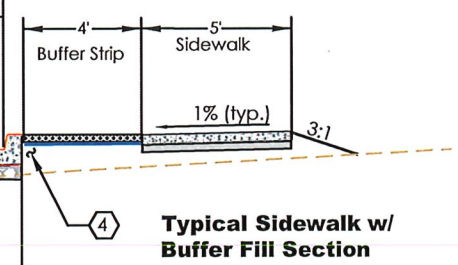

Typical Sidewalk w/ Buffer Fill Section

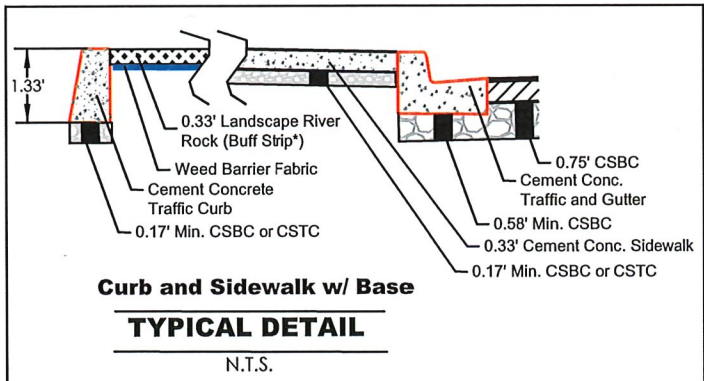

TYPICAL DETAIL
 Curb and Sidewalk w/ Base
 N.T.S.

- NOTES**
1. ALL DEPTHS SHOWN ARE COMPACTED DEPTHS.
 2. SEE SHEET T2 FOR PAVING CONSTRUCTION STAGING DETAILS.
 3. SUPERELEVATION VARIES FROM -4% TO 4%. SEE SUPERELEVATION TABLE ON PLAN SHEETS PP4 - PP8.
 4. EROSION CONTROL BLANKET ON SLOPES AS SHOWN IN PLANS. SEE SHEETS E1-4.
 5. ADDITIONAL CRUSHED SURFACING FOR SIDEWALK, DRIVEWAYS, AND CURBS IS INCIDENTAL TO ASSOCIATED ITEMS.
 6. WHERE EXISTING CONCRETE ROAD SLAB EXTENDS INTO NEW CSBC, SLAB SHALL BE BROKEN OR REMOVED AS DESCRIBED IN SPECIAL PROVISION "REMOVAL STRUCTURES AND OBSTRUCTIONS".
 7. SEE SHEET ___ FOR LUMINAIRE, DRAINAGE, AND TREE BOX DETAILS IN BUFFER STRIP.

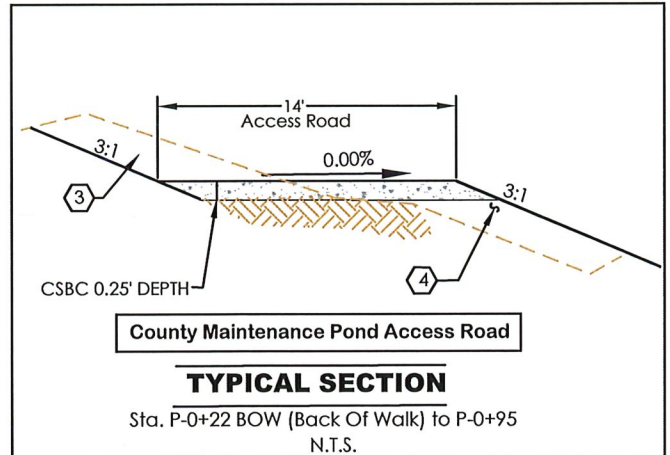

TYPICAL SECTION
 County Maintenance Pond Access Road
 Sta. P-0+22 BOW (Back Of Walk) to P-0+95
 N.T.S.

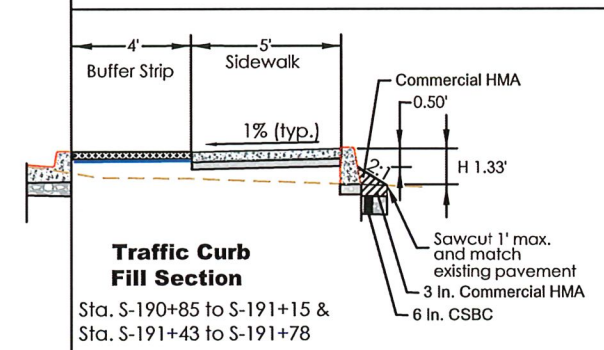

Traffic Curb Fill Section
 Sta. S-190+85 to S-191+15 &
 Sta. S-191+43 to S-191+78

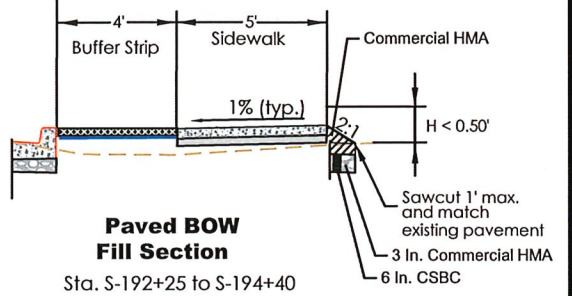

Paved BOW Fill Section
 Sta. S-192+25 to S-194+40

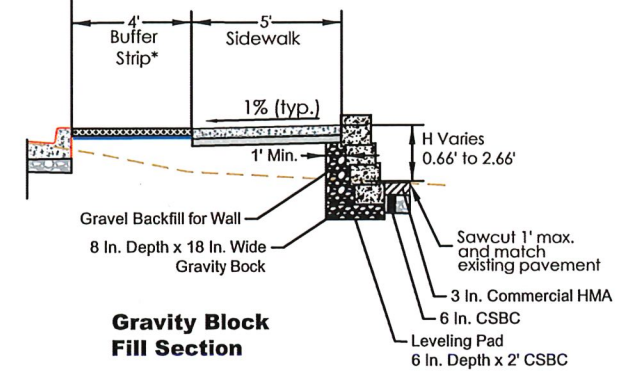

Gravity Block Fill Section

Gravity Block Locations

| STATION TO STATION | LENGTH | HEIGHT |
|----------------------|--------|----------------|
| S-188+90 to S-189+15 | 33' | 0.66' to 2.66' |
| S-189+50 to S-190+50 | 120' | 0.66' to 2.0' |

See Sheets G1 for Profiles

FILE NAME: \\ROADS\pw\home\Projects\CRP\CRP726_Goodwin Road\Civil3D 2018 Design WF\Shortcuts\Construction Drawings\CRP726 - 8-9 Typ Sections, Staging, Detail.dwg

| DESIGNED BY: | REVISIONS | DATE |
|-----------------------------|-----------|------|
| L. Dillin, PE | | |
| REVIEWED BY: J. Patrick, PE | | |
| DRAWN BY: L. Dillin, PE | | |
| PLOT DATE: 8/2/2022 | AS-BUILT | |

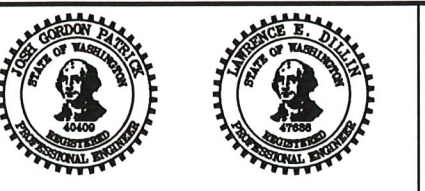

Chelan County
 Public Works Department
 316 Washington Street, Suite 402
 Wenatchee, Washington, 98801
 509.667.6415
 www.co.chelan.wa.us

GOODWIN ROAD
 Road Improvement Project

Chelan County
 PUBLIC WORKS

Typical Sections, Staging & Details

C.R.P. 726
 Dwg. No. T1
 Sheet No. 8